



2023 LEGIT Modified Rules

These rules are in effect as of January 1st, 2023 through December 31st, 2023

1. SAFETY EQUIPMENT: Rules apply at all times car is on track. Snell-rated SA2015 or SA2020 helmet required. *Fire retardant roll bar padding recommended in driver compartment.* SFI-approved full fire suit required. Fire retardant gloves, shoes and neck brace (or head and neck restraint) required. Right and left seat head supports required if using head and neck restraint system. *Recommended: Fire retardant head sock and underwear, collapsible steering shaft.* Driver-side window net required, minimum 16 inch by 20 inch ribbon or mesh style, and must be mounted to roll cage so latch is at top front of window. Maximum four inch tall visor attached to window net. Minimum two inch wide SFI-approved five point safety belt assembly required, must be mounted securely to main roll cage. *Recommended: Safety belts no more than two years old.* Kill switch required within easy reach of driver and must be clearly marked 'OFF' and 'ON'.

2. FRAME: 1964 or newer OEM perimeter American rear-wheel drive passenger car frame only. No sport car frames. Frame must be full and complete, cannot be widened or narrowed, and must be able to support roll cage on both sides. Exceptions are: weight jack in original center line of spring tower allowed; frame may be cut a maximum 36 inches forward from center of rear end housing; horns may be removed in front of steering box and notched maximum one inch at bottom for tie rod clearance; front crossmember may be notched and boxed for radiator and/or steering clearance; maximum seven inch wide opening in side of spring tower for spring removal. Maximum two inch wide by four inch tall frame stiffener may be welded directly to outside of left side frame rail, left top frame rail can be removed inside cockpit. Minimum wheelbase 108 inches, maximum 112 inches, both sides. Maximum overall width shall not exceed 78 inches from outside of tire to outside of tire. No part of frame or body can be lower than four inches from ground except front crossmember and rear underslung.

3. ROLL CAGE: Must consist of continuous hoops, minimum 1.75 inch O.D. tubing, with minimum wall thickness of 0.095 inch for main cage, frame-mounted in at least six places. *Recommended: low carbon or mild steel.* Must consist of a configuration of front, rear and top hoops connected by tubing on sides or side hoops. Driver's head must not protrude outside cage with helmet on. Roll cage must be securely supported and braced with minimum one cross bar in top halo. Foot protection bar required. Main cage no further forward than rear of engine. All bars forward of cage must be lower than hood.

4. DOOR BARS: All driver side door bars and uprights must be minimum 1.5 inch O.D. with 0.083 inch wall thickness. Minimum three driver side door bars, parallel to ground and perpendicular to driver, and welded to front and rear of roll cage. Passenger side must have at least one cross door bar, horizontal or angled, minimum 1.25 inch O.D. with 0.083 inch wall thickness, and one top horizontal door bar, minimum 1.5 inch O.D. with 0.083 inch wall thickness. Steel door plate, 18 gauge or 0.049 inch minimum thickness, must be securely welded to outside of driver side door bars and cover area from top door bar to bottom door bar and from rear hoop down-post to five inches in front of seat. Must be visible for inspection.

5. BODY: (See diagram) No composite or plastic body panels allowed except roof rock guard and hood scoop. Body and interior deck must be same width, front to rear, and parallel to OEM frame. Aluminum nose panel must be flat. Maximum 2.250 inch side fins allowed on aluminum nose. Five Star Md3 Modified plastic nosepieces allowed. Nose must be mounted in an approved manner and can extend no higher than front top of hood. Nose piece must remain inside confines of front bumper (exception is plastic valance), same width front to back, and be no lower than four inches below frame horns. Cooling holes allowed. Engine compartment must remain open (no side panels). Hood must cover radiator, be level or sloped down at front, enclosed and maximum two inches above interior deck at rear. Air cleaner top maximum six inches above hood. No panel in front of right door to engine compartment. No inner panels. No complete or half-car covers, rear tail cover allowed in personal pit area only. Must have front and rear roof support posts. Driver and passenger side windows must have at least 12 inch opening (height and width), measured at center of window, between lowest point at top and highest point at bottom. Sail panels may not extend ahead of back of seat. Solid sail panels only. Roof must be fiberglass or aluminum, full size, rounded down in all directions and mounted within 0.5 inch of main hoop. No dished roofs allowed. Driver roof hatch allowed. Maximum 1.5 inch rolled down rock guard allowed on roof front. Minimum two inch, maximum four inch roof sides allowed. Maximum one inch ridge down sides of roof. Maximum one inch rear roof stiffener (must face down). One piece rear spoiler allowed with GM 604 crate

engine only, maximum two inches in material height. Spoiler may have one inch rear stiffener, minimum one inch down from top. Spoiler must be attached to rear of sail panels, with one optional two-inch by five-inch triangular center support. No fins, lips, wings or vortex generators allowed. Maximum four inch plastic skirting allowed on bottom of doors, quarters and nose. Car number must be minimum four inches thick and 20 inches tall and clearly visible, on both sides and roof of car; six inches tall on front and rear.

6. DRIVER COMPARTMENT: Must have minimum three windshield bars in front of driver. Lexan or aluminum cowl panel in front of driver can be no wider than cockpit and no farther back than steering wheel. Minimum 0.125 inch aluminum, or 0.060 inch steel, complete floor pan required. Aluminum high-back seat only and must be bolted in, using minimum 0.375 inch bolts, next to left side frame rail and ahead of rear tires. Bottom of seat can be no lower than bottom of frame rail. Driver must be sealed off from track, driveline, engine, fuel cell, canisters and pumps. Oil coolers must not protrude above interior. Accumulators cannot be mounted between driver and left-side door bars. No driver-adjustable devices allowed while car is in competition except brake adjuster. No mirrors of any kind.

7. FRONT SUSPENSION: All components must be steel, unaltered OEM, in OEM location, and replaceable by OEM parts. Exceptions are: tubetype upper A-frames with or without aluminum or steel cross shaft, and mounts can be moved; stamped steel OEM replacement lower A-frames; rubber, nylon or steel lower A-frame bushings, no offset or bearing type; one welded shock mount on lower A-frame; no screw jack type shock mounts; OEM or OEM replacement rebuildable ball joints allowed. No screw-in lower ball joints. Lower A-frames must be right and left, and of same design. Lower A-frame mounts and bolt holes on frame must be within OEM specifications. No sway bar. Front drop chains allowed, mounted chassis or frame to lower A frame, must have slack during inspection. No unapproved stops of any kind allowed.

8. STEERING: No rack and pinion. All components must be steel, unaltered OEM, in OEM location. Exceptions are: outer tie rod end and adjustment sleeve may be replaced by a minimum 0.625 inch steel rod end and steel tube; spindles can be ground for brake caliper clearance only; unaltered, OEM or OEM replacement Pinto spindles allowed; Speedway Motors replacement spindle - part numbers 91034501 and 91034511 allowed; bolt on spindle savers allowed; steel steering shafts and knuckles only; driver compartment steering may be modified, must be kept on left side. Spindles must be right and left, and of same design. Quick release required - steering quickener and steering wheel may be aluminum. Idler arm, pitman arm, and center link must match frame.

9. SHOCKS: One steel, nonadjustable, unaltered shock per wheel. Maximum 7 inch stroke on front shocks and maximum 9 inch stroke on rear shocks. All shocks must completely collapse at any time. One additional shock allowed in pull-bar area. No shock can pre-load or pin any spring. No external or internal bumpers or stops. No threaded body, front coilover, air, or remote reservoir shocks. No Schrader or bladder type valve allowed. Front half may be shielded. One or all shocks may be claimed per event for \$100 each.

10. SPRINGS: One steel, non-progressive closed end coil spring per wheel only. One additional spring allowed on pull bar, may be progressive. Minimum 4.5 inches O.D. Front coil springs must be 9.5 inch free height with 0.5 inch tolerance. Rear coil springs must be 11-16 inch free height with 0.5 inch tolerance. No torsion bars, air bags, inner liners or spring rubbers allowed. Steel or composite leaf spring allowed.

11. REAR SUSPENSION: Rear of frame may be altered to accept leaf or coil springs. All components must be steel. All trailing arms/link bars must be solid tubing. One mechanical traction pull bar allowed. Rubber bumpers allowed on pull bar or panhard bar only. Minimum 19 inch long panhard bar measured straight center to center. One bracket mounted solid to axle tube with lower link OR one floating birdcage with upper and lower links allowed per side. Additional shock/coilover eliminator clamp bracket solidly mounted to axle tube is allowed per side. Steel coil-over eliminators, or steel or aluminum coil-over kits allowed - must conform to shock and spring rules. Shocks and coil-over eliminators must be mounted to birdcage or bracket below bottom of axle tube and to upper frame rail. Spring using jack bolt may be mounted directly to top of axle housing. Solid safety chains securely mounted from upper frame rails directly to axle tubes allowed (cannot be mounted to any floating device, must have slack during inspection). No independent rear suspension. No covers on any suspension components. No lift, brake or sway bars. No suspension stops or adjustable underslung of any kind.

12. REAR END: Any steel approved OEM passenger car or truck rear end allowed (housing and carrier) with steel spool (full or mini). Quick change allowed and must use 10" ring gear with aluminum or steel spool, steel axle tubes, minimum one inch wide spur gears and bolt on rear cover. Safety hubs (floater) allowed. Steel axles only. All additional components must be steel, except lowering blocks, axle caps, U-joint caps, and one piece drive flange. One inch inspection hole required in housings. No scalloped ring gears, cambered rear ends, heavyweight axle tubes (max .250" wall) or housing braces.

13. BUMPERS: (See diagram) Steel bumpers must be on front and rear and welded, or securely mounted with minimum 0.375 inch bolts. Rear bumper must be capped, constructed of minimum 1.25 inch O.D. tubing with 0.095 wall thickness (similar to diagram), maximum six inches beyond rear deck, no wider than five inches outside of rear frame rails. If wider than five inches outside rear frame rails must be bent forward 90 degrees, or constructed in a loop design. Must have at least one upright, minimum 1.25 inch with 0.065 wall thickness, from bumper to fuel cell guard. Two-bar front bumper must be minimum 1.25 inch O.D. tubing with minimum 0.065 wall thickness (maximum 0.095 inch) mounted frame-end to frame-end, no wider than width of material outside frame horns and with bottom loop parallel to ground. Top bar must be directly above bottom bar, minimum 6.5 inches apart, measured center to center.

14. TIRES/WHEELS: Must use unaltered Hoosier Race tire, G60-15 (IMCA stamp not required), or American Racer G60-15 KK-704. No chemical softening or conditioning of tires. Tires may be ground, straight sided or grooved. All wheels must be unaltered and display wheel manufacturer decal. Aluminum wheel spacers only. May use bead lock, on right rear only. External, steel bead lock only and it cannot make wheel any narrower than eight inches and no wider than 8.75 inches. Must use only steel bolts. Foam type or securely bolted plastic outer mud cover allowed on right side wheels. Outer mud cover mounting tabs and rings must be integral to the wheel or bead lock or be securely welded to wheel. Aluminum inner mud cover allowed on left rear only. Rim-mounted bleeder valves allowed. Steel lug nuts only.

15. BRAKES: Must be steel approved OEM, operative four wheel, drum or disc. Must maintain minimum OEM dimensions for hubs/rotors and calipers, cannot be lightened. Bolt pattern may be changed. Larger studs allowed. Rear rotors may be aftermarket 0.81 inch thickness (new). Vented solid surface rotors only, no scalloped or ceramic coated rotors. No brake shut-off or pressure sensitive devices. One front to rear proportioning device allowed. Brake lines must be visible. Single link brake caliper floater allowed on rear, one per side.

16. EXHAUST: Round tube headers only. All primary header tubes must enter directly into one collector at same point at end of header. Collector and turn down length maximum nineteen inches total. Mufflers allowed. All exhaust must go through mufflers, two per car, one per header. Valve covers and headers may be modified for pan-evac system. No anti-reversion headers or mufflers, exhaust sensors, merge collectors, extensions, inserts, cones or balance tubes.

17. FUEL SYSTEM: Mechanical or belt driven fuel pump only and must be mounted at front of engine. Racing fuel cell required, maximum 32 gallon capacity, must be in minimum 20 gauge steel container. Cell must be securely mounted behind rear axle, between rear tires, minimum of four inches ahead of bumper, minimum of 10 inches above ground. Must mount with minimum one inch square tubing or two solid steel straps around entire cell, two inches wide and 0.125 inch thick. All cell mounts must be steel, securely welded to frame/cage. Protective tubing must cover rear and extend past both sides of cell. No part of cell shall be lower than protective tubing. Fuel cell vents, including cap vent, must have check valves. If fuel cell does not have aircraft style positive seal filler neck/cap system - a flapper, spring or ball type filler rollover valve is required. Pickup must be on top or right side of cell. One fuel filter allowed. No cool cans. Air cleaner top/stud cannot direct air into carburetor. No top flow air cleaner housings or cold air boxes. One naturally aspirated two- or fourbarrel carburetor only with Holley OEM or OEM replacement booster. Aerosol carburetor is allowed. No ICT type boosters allowed. *Fuel shutoff recommended.*

CLAIM ENGINE: One carburetor adapter/spacer allowed, maximum 2.20 inches thick, including gaskets. No adjustable throttle bore or sleeve type carburetor spacers.

GM CRATE ENGINE: If carburetor spacer is used on crate, must use Speedway Motors part #545-64940 or Moroso part #64940 carburetor spacer.

18. FUEL: Gasoline, racing fuel or 99.9% pure methanol allowed. No E85. NO fuel additives of any kind allowed. Fuel sample may be taken from any car at any time.

19.WEIGHT: Minimum weight limit of 2,450 pounds, no tolerance, after race with driver in car. No ballast and/or loose objects in driver compartment, above interior deck or outside body. Ballast must be securely mounted to frame or roll cage and painted white with car number on it. Must be attached with at least two 0.5 inch bolts. No titanium, magnesium, carbon fiber or tungsten products. Exceptions are: carbon fiber rock guard, hood scoop, and magnesium quick change center section. Solid steel fasteners only.

20.BATTERY/STARTER: One 12 volt battery only. No lithium batteries. Must be securely mounted between frame rails, and positive terminal must be covered. Car must have capability of starting without being pushed or pulled. Car must leave initial staging area on demand, unaided, or go to rear of that race. Reverse-mount starters with OEM case transmissions only, see transmission rules for specifics.

21. GAUGES/ELECTRONICS: Scoring transponder must be mounted on bottom right rear axle tube. No cell phones, unapproved cameras, transmitting or listening devices (exception is one-way Race Receiver radio by officials), timing retard controls, or digital gauges (including tach). No electronic monitoring computer devices capable of storing or transmitting information except memory recall analog tach. Crate engine must use maximum 6,800 rpm rev-limiter. Claim engine must use maximum 7,800 rpm rev-limiter. This may be accomplished using one unaltered, non-adjustable, 12 volt ignition box with one high-end revlimiter chip, an external setting, or an internal preset. No electronic advance curve ignitions allowed. No unapproved or additional ignition accessories allowed. All components must be out of reach of driver, but with rev control easily accessible facing up or out for inspection. All wiring must be visible for inspection. No magnetos or crank triggers. No electronic traction control devices

22.TRANSMISSION/DRIVESHAFT: Must have at least two forward gears and one reverse, plus a neutral position. With engine running and car in still position, must be able to engage car in gear and move forward, then backward. OEM production type approved aftermarket transmissions allowed (Bert, Brinn, Falcon, RaceGator, Mitchell Machine, Jerico) No Ball Spline Transmissions - two-speed, three-speed, four-speed and automatic. No five speed (or more) transmissions, 'in and out' boxes, or quick change devices allowed. Functioning shift levers must be in OEM location on all OEM production type transmissions. All belt drive pumps must be mounted on front of engine. Flexplates must be full, steel, unaltered OEM, or OEM replacement. Flywheel/flexplate must bolt to engine between clutch assembly and crankshaft and all driveline components within bellhousing must rotate while car is in any gear. Transmission must be one of the following designs: OEM Manual: Must have a standard OEM case and working disc-type clutch or approved cone or disc-type coupler inside an explosionproof steel bellhousing. One flywheel only, minimum 8.5 inch diameter. Diameter of clutch disc must be a minimum of 5.5 inches. Clutch assembly must be steel, except housing, which must be steel and/ or aluminum. Bellhousing can have only a hole for throwout bearing lever or hose, must be 270 degrees around top of clutch and flywheel area. Standard or reverse mount starter allowed, must directly engage flywheel. Automatic: Must remain in OEM or OEM replacement case, with a functioning OEM appearing pump. Aluminum OEM bellhousing may be replaced with aftermarket explosion-proof steel or aluminum bellhousing. Original OEM bellhousing must have approved scattershield constructed of minimum 0.125 inch by three inch steel, (1) 270 degrees around flexplate. Aftermarket Manual: Must be approved, aluminum case, with internal clutch. Must bolt to explosion-proof steel bellhousing, and use full, steel, unaltered OEM or OEM replacement flexplate with starter mounted in OEM location. No coatings or paint allowed on transmission case. No ball-spline transmissions. Drive Shaft: Steel slip-yokes only. Minimum two inch diameter steel drive shaft and must be painted white. 360-degree drive shaft loop required and must be constructed of at least 0.25 inch by two inch steel, or one inch tubing, mounted six inches back from front U-joint.

23.ENGINE COMPARTMENT: Rear of engine (bellhousing flange) must be mounted at least 72 inches forward from centerline of rear axle. Engine offset must be kept within two inches of centerline of front crossmember with engine level. Minimum 11 inch engine height from ground to center of crankshaft. Radiator must be mounted in front of engine. Cooling system may be modified. Overflow tubes must be directed to ground between frame rails. No vacuum pumps. All belt driven accessories must be on front of engine.

24.ENGINE SPECIFICATIONS: All cars utilizing the GM604 crate engine must clearly display on both front roof posts the Chevrolet Performance emblem.

(A) CRATE ENGINE: Must use unaltered sealed GM 604 crate engine – NO EXCEPTIONS. Upon inspection, any different, altered or missing GM seal bolts or Cable-Loks will result in penalty/disqualification. GM seal bolt exception is LEGIT approved and issued Cable-Lok repair system, oil pan may be replaced by LEGIT certified repair center with approved pan and pickup. Any driver using crate engine cannot claim engine or have engine claimed. During same season, no driver is allowed to claim an engine after competing with a crate. If a driver switches to a crate after claiming an engine, the crate engine is then claimable.

(B) CLAIM ENGINE: Any American make steel engine block allowed. Aftermarket and OEM performance blocks allowed. Cast iron or aluminum intake manifolds only. Steel cylinder heads and oil pan only. Flat tappet cam/lifters and stud-mounted rocker arms only. Magnetic steel retainers only. No shaft, pedestal, or offset rocker arms, titanium engine components, stud girdles or mushroom lifters. Lifter diameter and configuration must match OEM passenger block. OEM firing order cannot be changed (GM: 1-8-4-3-6-5-7-2). All engines must be able to be used in conventional passenger car without alterations. Engine mounts cannot be removed or altered. Castings and fittings must not be changed. No machine work on outside of engine (no lightweight engine blocks). 'Wet' sump oiling system only. External oil pumps go with engine if claimed.

25. ENGINE CLAIMING RULES:

(A) \$1,050 cash, or \$100 and exchange, claim on engine, flywheel and balancing plates (\$25 goes to wrecker and \$25 to official for each engine). Claimed driver has option of accepting cash, or exchanging engines with claiming driver.

(B) Claim does not include - 1. clutch, 2. pressure plate, 3. bellhousing, 4. headers, 5. carburetor, 6. starter, 7. motor mounts, 8. oil/temp. sending units, 9. carburetor spacer, 10. fan and pulleys, 11. clutch ball, 12. clutch arm, 13. throw out bearing, 14. dip stick, 15. water pump, 16. fuel pump, rod and plate, 17. distributor, 18. plug wires, 19. water outlet and restrictor, 20. breathers.

26. EIRI: (Except in rare instances) Decisions of LEGIT Officials are final and binding without exception.

LEGIT MODIFIED BODY DIMENSIONS 2023

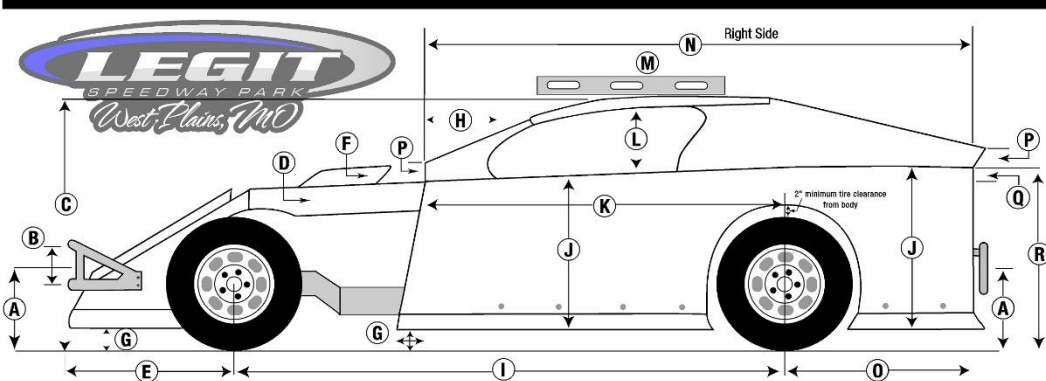

A 20" max. 16" min. (ground to center of bumpers, front and rear)

B 6.5" min. (center to center)

C 54" max. roll cage, 56" max roof; 42" min. both

D Hood 6" max. drop (sides), sealed off from driver's compartment and max. 6" rake.

E 36" max.

F 6" max. scoop cannot extend past front of hood.

G 4" min. ground clearance; Door may extend max. 6" past block at bottom, both sides.

H 19" max., must be same on both sides.

I 112" max. 108" min.

J 31" max. 24" min.

K 72" max. or not past back of block at top. Left side may extend forward to cover foot box.

L 18" max. 12" min. opening, both sides.

M With level, must have no more than 2" clearance at rear of roof and 5" at top front.

N 120" max. 106" min.

O 48" max. 34" min.

P 4" max. at front and rear, gradual slope from roof to this point.

Q Interior slope is 6" max. front to rear and flat across. If flat at front half of interior you have used up 50% of your 6" so from behind driver to rear you may only have 3". Top of interior must be flush with top of door and quarter panels. Optional escape hatch from driver to passenger door allowed.

R 38" max. 28" min.

S Min. 24" nose must be flat and flush with sides.

T 66" max. 24" min., must cover radiator

U 52" max. 44" min. (includes sides)

V 56" max. 47" min.

W Tires max 1" inside body both sides.

X 66" max. 53" min. same front to back.

All body measurements are max. unless otherwise specified. Dimensions have zero tolerance.

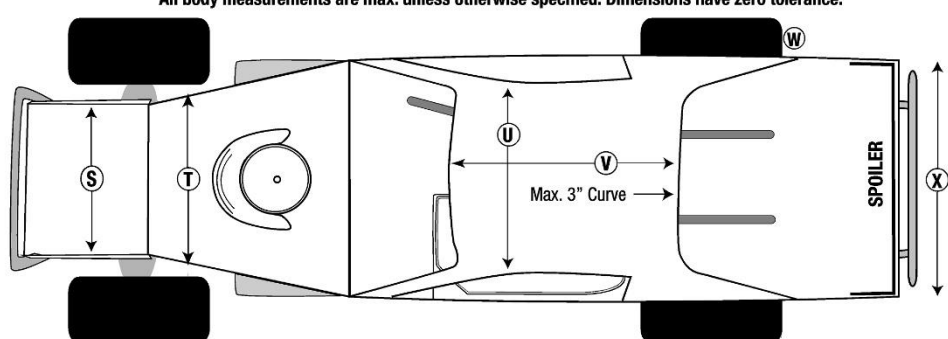

S Min. 24" nose must be flat and flush with sides.

T 66" max. 24" min., must cover radiator

U 52" max. 44" min. (includes sides)

V 56" max. 47" min.

W Tires max 1" inside body both sides.

X 66" max. 53" min. same front to back.

SAIL PANEL must be solid

1" max. curve at center no tolerance

Max 2"

1" Max Ridge

Sail Panel

Roof

Max 4" bow at center of sail panel. No bends or breaks

Interior

Body

REAR FILLER PANEL: 8" min. / 90 degree angle. Must be solid, attached to deck, extend to quarter panels, securely fastened.

SAIL PANELS: Must slope down from rear edge of roof and extend from roof to rear of car and be the same on both sides. May extend 2" maximum past rear edge of interior deck. Must mount to outside of, and can be no wider than interior deck. Must mount under roof sides.